

OPTIMIZATION OF MICROCONTROLLER ARCHITECTURES AND IMPROVEMENT OF THEIR EFFICIENCY IN IOT-BASED INTELLIGENT SYSTEMS

Jabborov A.B

Tashkent State Technical University, Tashkent, Republic of Uzbekistan

email: jabborovrqt@gmail.com

Umarov S.O

Student of group 83-24 (RQT)

Abstract: *This article provides a scientific analysis of the architecture of microcontrollers used in IoT-based intelligent systems and the issues related to improving their efficiency. The internal structure, main components, and functional capabilities of microcontrollers are examined, and their role in real-time operating systems is highlighted. In addition, the Arduino platform is considered as an example to analyze the simplification of microcontroller usage and the possibilities for rapid system development. The technical characteristics of modern microcontrollers based on AVR and ARM Cortex architectures are compared, and their efficiency in IoT systems is evaluated. According to the research results, it is determined that increasing the level of integration, energy efficiency, and flexibility of microcontrollers can significantly improve the overall performance of intelligent systems.*

Keywords: *microcontrollers, IoT, intelligent systems, real-time systems, network architecture, energy efficiency, optimization, embedded systems, sensors, automation.*

Microcontrollers are one of the main functional elements of modern digital and automated systems.

They are usually not used as standalone devices but are applied as part of complex electronic systems and control units.

All main components of a microcontroller, including the central processor, random access memory, permanent memory, input/output ports, timers, counters, and various interface modules, are integrated within a single microchip.

Such a level of integration increases system compactness, reduces energy consumption, and ensures overall reliability of the device [1].

The main function of microcontrollers is to control external devices based on a pre-written program, receive data from various sensors, process it, and, when necessary, transmit it to other devices. In this regard, microcontrollers are especially important for systems operating in real-time.

They are typically designed to perform specific tasks and are widely used in automation, robotics, industrial control systems, household appliances, and IoT-based devices.

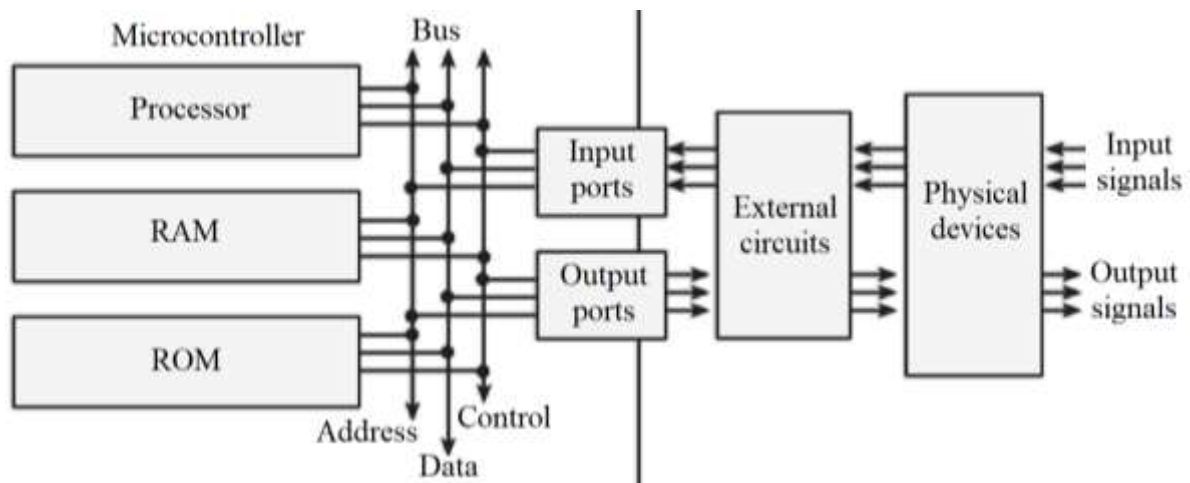

General structure of a microcontroller and its interaction with external devices.

Controllers, on the other hand, are designed based on microcontrollers to solve a specific task or a group of related tasks. Their architecture is optimized to ensure maximum efficiency and speed, and their ability to connect additional devices is usually limited. In most cases, the programs executed in controllers are stored in permanent memory and do not change during system operation.

This approach ensures stable system performance but somewhat reduces its flexibility. In the early stages of using microcontrollers, their application required complex technical knowledge. In particular, the user needed a deep understanding of circuit design fundamentals, processor architecture, assembly-level programming, and electronic system development. In addition, special programming devices, debugging tools, and other auxiliary equipment were required. These factors significantly limited the widespread use of microcontrollers.

In recent years, the emergence of open-architecture platforms, particularly the Arduino system, has fundamentally changed this situation. The Arduino platform has simplified working with microcontrollers, making it possible to develop various electronic devices without requiring complex technical knowledge [3]. This platform consists of an integrated set of hardware and software, including a microcontroller, a development environment, and various software libraries. Arduino microcontrollers are equipped with special pins and interfaces for interaction with external devices, and they can be connected to a computer via USB and programmed without additional programming devices.

This significantly simplifies the processes of system development, configuration, and implementation. Moreover, the availability of numerous ready-made software libraries for the platform facilitates working with sensors, actuators, and communication modules, enabling rapid development of IoT-based systems.

Modern microcontrollers are manufactured based on various architectures. In addition to the widely used AVR microcontrollers, today microcontrollers belonging to the ARM Cortex family stand out due to their high performance and extensive functional capabilities [2].

In particular, ARM Cortex-M3, M4, and M7 cores are characterized by high processing speed, large memory capacity, and advanced interface systems.

This makes them an effective solution for use in IoT systems that require complex computations and real-time operation. Thus, microcontrollers serve as the main control element of modern intelligent systems, including IoT-based energy-efficient lighting systems.

Their high level of integration, energy efficiency, and flexibility enable their wide application across various fields and provide the necessary technological foundation for efficient management of complex systems [4-5].

Conclusion. Studies show that microcontrollers are the main control element of IoT-based intelligent systems, and their architecture directly affects the overall system efficiency.

The high level of integration, compactness, and energy efficiency of microcontrollers enable their widespread use in real-time operating systems. Open platforms such as Arduino simplify the use of microcontrollers and provide a basis for the rapid development of innovative solutions.

At the same time, modern ARM Cortex-based microcontrollers are effectively used in complex IoT systems due to their high performance. In general, improving microcontroller architecture and increasing their operational efficiency play an important role in enhancing the stability, energy efficiency, and functional capabilities of IoT systems.

REFERENCES:

1. Mazidi M. A., Mazidi J. G., McKinlay R. D. The 8051 Microcontroller and Embedded Systems, Pearson, 2006.
2. Yiu J. The Definitive Guide to ARM Cortex-M3 and Cortex-M4 Processors, Newnes, 2013.
3. Banzi M., Shiloh M. Getting Started with Arduino, Maker Media, 2014.
4. Al-Fuqaha A., Guizani M., Mohammadi M., Aledhari M., Ayyash M. Internet of Things: A Survey on Enabling Technologies, Protocols, and Applications, IEEE Communications Surveys & Tutorials, 2015.
5. Gagliardi R., et al. Smart street lighting systems: A survey on technologies and applications, IEEE, 2018.